

MICRO DIAPHRAGM LIQUID PUMP

NF 1.5



NF 1.5 KPDC-M



NF 1.5 KPDCB-4



NF 1.5 KP51DCB-4

Concept

KNF micro diaphragm liquid pumps are based on the principle of the oscillating displacement pump which is remarkably simple in design. The circular power from the motor is converted into vertical movement by an eccentric. This motion is then transferred to a diaphragm by means of a connecting rod which, in conjunction with an inlet and outlet valve, creates a pumping action.

The NF 1.5 liquid pumps can be mounted in any position. They deliver up to 60 mL/min and will operate against a max. pressure of 85 psig.

The KNF modular system contains a wide standard range of materials, motors, voltages and frequencies to enable the selection of an optimal solution for your application.

Features

Small and powerful

Micro design and maximum performance resulting from built-in technology are the outstanding characteristics of these products.

Self-priming and excellent for pressure

Sophisticated diaphragm technology and precise valve structures enable performances of 9 in.Hg suction or 85 psig pressure.

Extreme chemical resistance

The use of the materials PTFE, (TFM) PVDF, EPDM for the parts which come in contact with the liquid allows many neutral or corrosive liquid to be pumped.

Dry running, durable and maintenance free

The carefully considered design of these pumps allows them to be run dry and ensures safe operation and a long life even under the most severe conditions.

Areas of use

The versatility of KNF pumps allows a wide field of applications to be covered. Over many years our pumps have proved themselves in the following areas:

Analysers

- Medical / pharmaceutical
- Environmental / water treatment
- Food / toxicology

Laboratory

- Filtration
- Chromatography

Cleaning industry

- Cuvette cleaning
- Sterilizers
- Industrial washing machines

Printing

- Ink jet printing
- Photographic / film development

Other applications for micro-diaphragm liquid pumps include: fuel cells, hydrogen generators, CD coating, dental technology, textiles and many more.

PERFORMANCES			
Type	Flow rate (mL/min)	max. Suction height (in.Hg)	max. Pressure head (psig)
NF 1.5 DC-M	60	9	85
NF 1.5 DCB-4	5–50	9	85

THE KNF MODULAR CONCEPT OF SELECTION

General note

This Data Sheet provides an overview of the options with our NF 1.5. Certain standard options will be explained in more detail where necessary.

Flow curves

The flow curves illustrate how the flow rate alters in relation to the pressures before and after the pump. In the case of a combination of both we would be very happy to advise what the expected flow rate would be.

The values given in the curves are dependant upon the liquid, choice of head materials and the type of hoses being used. Therefore a certain deviation is to be expected. The flow rate is measured with water at 20°C.

Modules

Our versatile self-selection program allows you to personally determine the optimum characteristics that you require from your pump. Select your diaphragm pump from the following characteristics:

PUMP TYPE			
Basic Model	1	2	3
NF 1.5			
Example	KP	DCB-4	10...28V

1 MATERIALS OF HEAD COMPONENTS		
KP	Head Valves Diaphragm	PP EPDM PTFE covered
KT	Head Valves Diaphragm	PP FFKM PTFE covered
TT	Head Valves Diaphragm	PVDF FFKM PTFE covered

2 MOTORS	
DC-M	Direct current motor
DCB-4	Brushless direct current motor

3 VOLTAGES	
12 / 24V	for direct current motor
10..28V	for brushless direct current motor

1 Materials of head components

KNF Flodos offers a wide range of different materials for those parts which come in contact with the liquid thus allowing the possibility of pumping most liquids.

2 Motors

- **DC-M** Direct current motor
- **DCB-4** Brushless direct current motor, this type of motor has no brushes which can wear down thus giving it a lifetime comparable with an AC motor. The small size, the flow rate adjustability and the impulse generator are some more advantages to the other DC motors.

LEADS			
Function	Leads color	Signal name	Signal
+ Voltage	red	+Vs	10 .. 28V DC
- Voltage	black	-Vs/GND	-
Speed control input signal	white	Vctrl	0.3 ... 5V DC
Impulse generator	green	FG	6 Pulse / mech. rotation

3 Voltages

Choose from the different electrical connection possibilities. Special variations are available.

NF 1.5 DC-M

PERFORMANCE

Type	Flow rate atm. Pressure (mL/min)	Max Suction height (in.Hg)	Max Pressure head (psig)
NF 1.5 DC-M	60	9	85

Type	DC-M
Voltage (V)	12 / 24
Power rating (W)	2.16
I max load. (A)	0.18 / 0.09
I max. (A)	0.24 / 0.12
EMV-Guideline	EN 55022 EN 55011
Weight (g)	57
Motor protection factor	IP 30

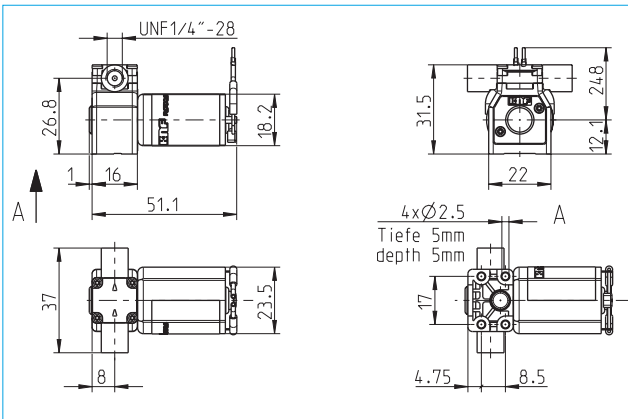

NF 1.5 DCB-4

PERFORMANCE

Type	Flow rate atm. Pressure (mL/min)	Max Suction height (in.Hg)	Max Pressure head (psig)
NF 1.5 DCB-4	5-50	9	85

Type	DCB-4
Voltage (V)	10 .. 28
Power rating (W)	1.5
I max load. (A)	0.15 .. 0.055
I max. (A)	0.45
EMV-Guideline	EN 61000-6-2 EN 61000-6-3
Weight (g)	50
Motor protection factor	IP 40

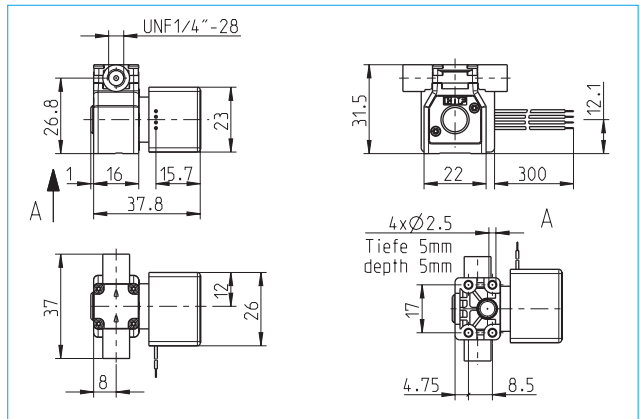

NF 1.5 DC-M FLOW CURVE

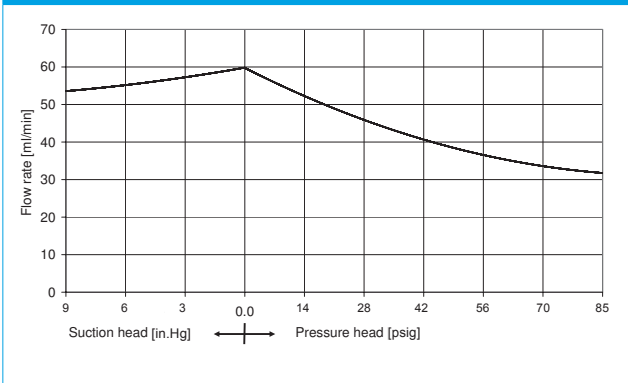

NF 1.5 DCB-4 FLOW CURVE

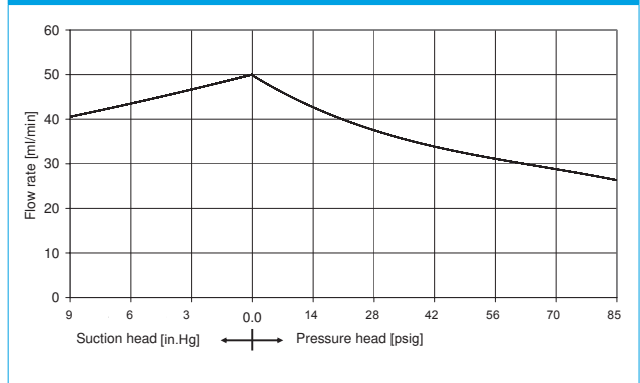

NF 1.5 DCB-4 CONTROL CURVE

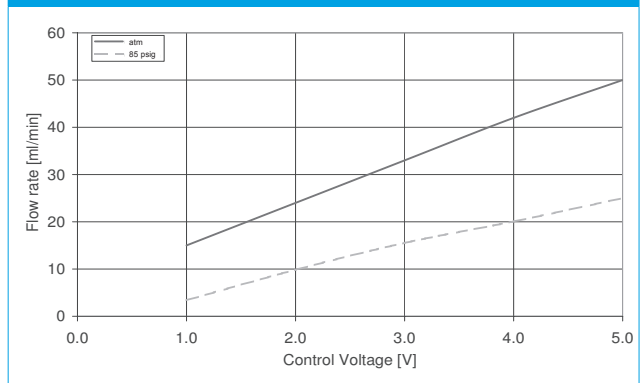

OPTIONS, ACCESSORIES

Further options

- Other head materials
- Motors with special voltages or frequencies
- Specific customers requirements such as special connections (Molex, AMP, etc.)
- DCB motor with 2 leads (12 and 24 V)

Diaphragm pressure control valve

The pressure control valve can be used for a more accurate control of flow against a fluctuating back pressure, metering into a vacuum and from a pressurised system. It can save pumps, plumbings and other components from damage.



Pulsation damper

This very versatile pulsation damper reduces the vibration in hoses and pipes and it helps to remove pulsation which is preventing the system from functioning correctly. It also protects instrumentation connected after the pump.



Filter

KNF filters protect both pumps and other upstream instrumentation and hydraulic circuits against particulate, crystals and fibres which can impede optimum operation.



Other accessories

- Tubing
- Shock mounts

NSF National Sanitary Foundation

NSF is market leader in the development and controlling of standards relevant for equipment used for handling foodstuffs. By using different toxicological tests our products will be certified according to the standard NSF/ANSI 169. This certification will confirm that all of the pumps with the code .51 are certified for the use with foods/consumables. In addition to this it also means that the pumps are constructed with wetted parts which come with a FDA* declaration of conformity. A yearly audit from NSF will be carried out to ensure that these standards are being maintained. A list of the various products are available on request.



* FDA = Food and Drug Administration