

# Operating and Installation Instructions

# Swing Piston Compressors and Vacuum Pumps

Type Range:

**UNPK09**

**UNPK09.1**

**UNPK09DC**

**UNPK09.2**

**UNPK09.1.2**

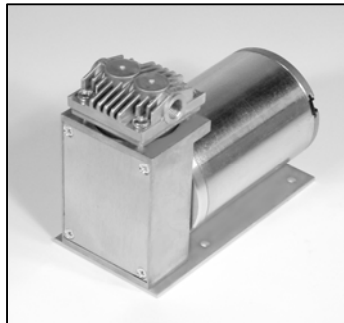

*Fig. 1: UNPK09*

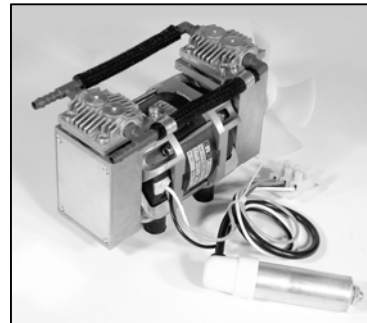

*Fig. 2: UNPK09.1.2*

You have selected a high-quality KNF product; the following tips will help you operate it safely and reliably over a long period of time. Carefully study the Operating and Installation Instructions before using the pumps and observe at all times the relevant instructions to avoid dangerous situations. The manual was produced for the serial pumps stated above. With customer-specified projects (pump types starting with "PU" or "MPU") there could be differences in detail. For customer-specified projects please therefore take into account any agreed technical specifications, as well as these instructions.

## List of Contents

## Page

1. Description, Operating Conditions.....	2
2. Safety.....	3
3. Installation.....	4
4. Operation.....	5
5. Servicing.....	6
6. Cleaning.....	10
7. Trouble Shooting.....	11
8. Spare parts.....	12
9. Accessories.....	12
10. Tables.....	13
11. Product Return.....	14

KNF Neuberger, Inc  
2 Black Forest Rd  
Trenton, NJ 08691-1810

Phone: 609-890-8600  
Fax: 609-890-8323

[www.knf.com/usa.htm](http://www.knf.com/usa.htm)

Ident#121576-125598  
Revision (09/12)

## 1. Description, Operating Conditions

KNF pumps in the NPK range transfer, evacuate and compress oil-free. In operation they are maintenance-free. The noise levels from the pumps are ca. 60 dB (A) (one head model, with hose connectors and inlet filter fitted).

### 1.1. Electrical Equipment

See the motor-plate for full electrical data.

The protection class of standard version is IP00.

The ac-motors used are fitted as standard with a thermal switch to protect against overloading.

### 1.2. Operating Conditions

Handling air at temperatures between + 5 °C ...+ 40 °C.

KNF swing piston compressors and vacuum pumps must not be used for liquids. You will find suitable liquid pumps in our Product Program.

For maximum permissible operating pressure, ultimate vacuum, and flow capacity see section 10.

The KNF swing piston compressors and vacuum pumps must not be used in areas where there is a danger of explosion.

If your potential application lies outside the above limits discuss it with our technical adviser (see last page for contact telephone number).

### 1.3. Ambient Conditions

When the pump is operating the following ambient conditions must be maintained:

- Ambient temperature during operation: between + 5 °C ...+ 40 °C.
- The pumps must be protected from the effects of dust and water.
- During operation an adequate supply of air for cooling must be provided.
- The pumps must not be used in areas where there is a danger of explosion.

## 2. Safety

**The standard pumps have Protection Class 00, and so offer no protection against contact or foreign bodies. It is therefore essential to provide protection for persons against contact with live parts (e.g. electrical connections, motor windings), and moving parts (e.g. fan). Protection against the entry of foreign bodies must also be provided.**

**The pump has no protection against water. In this case too, as far as is relevant, measures to protect the pump must be taken before putting it into service.**

Note that the pumps may only be used for their intended purpose.

The pumps must not be used in areas where there is a danger of explosion.

Components connected to the pump must be designed to withstand the pneumatic performance of the pump.

Take care that safety regulations are observed when connecting the pump to the electricity supply.

For pumps with a thermal switch: when the operation of the pump is interrupted by the thermal switch, the pump will re-start automatically after cooling down. Take all care necessary to prevent this leading to a dangerous situation.

Use only original KNF spare parts.

Pumps in the NPK 09 range conform to the safety regulations of the EC Low Voltage Directive 2006/95/EC, and of the EC Directive 2004/108/EC concerning Electromagnetic Compatibility.

EC Directives / Standards

For the purposes of the Machinery Directive 2006/42/EC, pumps are "partly completed machinery," and are therefore to be regarded as not ready for use. Partly completed machinery may not be commissioned until such time as it has been determined that the machine in which the partly completed machinery is to be assembled is in conformity with the provisions of the Machinery Directive 2006/42/EC. The essential requirements of Annex I of Directive 2006/42/EC (general principles) are applied and observed.



The pumps conform to the EC Directive 2004/108/EC concerning Electromagnetic Compatibility.

The following harmonized standards have been used:

UNPK09 DC	UNPK09 AC
DIN EN 55014-1/2	DIN EN 55014-1/2
DIN EN 60034-1	DIN EN 61000-3-2/3
	DIN EN 60335-1

Tab. 1

### 3. Installation

**Pumps in the NPK 09 range are OEM models intended for installation in equipment. When installing them make certain that accident prevention regulations, and safety instructions, including those for subsequent operation are observed. The safety instructions in section 2 must be observed.**

**Mechanical** The dimensions of the mountings are given in Data Sheet E 300.  
Install the pump so that the fan can draw in sufficient cooling air.  
Install the pump so as accidental finger contact is with the fan is impossible.  
Fit the pump at the highest point in the system, so that condensate cannot collect in the head of the pump - that prolongs working life.

**Electrical** **When making the electrical installation the safety regulations must be observed. In particular make sure that the electricity supply is isolated before trying to connect the pump.**

Compare the supply data with the data on the motor-plate. The voltage must not vary by more than +10% and -10% from that shown on the type-plate.

The earth (ground) wire must be connected to the motor (not necessary on dc motors up to 24 V).

For brushed dc motor lead wires connection:

- Red: V+
- Black: Ground

**Caution:** → **Incorrect lead wire connection will damage motor.**

For brushless dc motor lead wire connection:

- Red: V+
- Black: Ground
- White: Voltage control 0-5 V DC (4 wire motor only)
- Green: Frequency output (4 wire motor only)

**Caution:** → **Incorrect lead wire connection will damage motor.**

In the electrical installation, arrangements (complying with EN 60335-1) must be made for disconnecting the pump motor from the electrical supply.

The pump must be installed so that contact with live parts (connection, possibly windings) is impossible.

We recommend that a fuse is installed in the supply circuit; the operating current is given in Data Sheet E 300.

**Pneumatic** Remove the protection plugs from the port threads.

The accessories silencer/filter and hose connectors (where applicable) are screwed into the port threads.

Connect the suction and pressure lines.

Arrange the suction and pressure lines so that condensate cannot run into the pump.

## 4. Operation

The pump must not start against pressure or vacuum. When it is switched on the pressure in the suction and pressure lines must be atmospheric. This also applies when the pump restarts after the power has been cut off for a short period.

The maximum permissible operating pressure (see section 10) must not be exceeded.

To prevent the maximum permissible operating pressure being exceeded, restriction or control of the air or gas flow should only be carried out in the suction line.

If restriction or control of the air or gas flow is made on the pressure side ensure that the maximum permissible operating pressure is not exceeded.

When the pump is at a standstill the inlet and exhaust must be at normal atmospheric pressure.

Change the filter (accessories) if it is dirty.

The piston seals, and to a lesser extent the valve plates are the only parts of the pump subject to wear. Wear is usually indicated by a drastic reduction in the pneumatic performance. When replacing parts proceed as described in section 5.

Ambient conditions: see section 1.3.

### 5. Servicing

**Before working on the pump, isolate the power supply securely, then check that the lines are not live.**

The piston seal, and to a lesser extent the valve plates are the only parts of the pump subject to wear. They are simple to change. When changing the piston seal, check the valve plates for damage (tongues bent, corrosion).

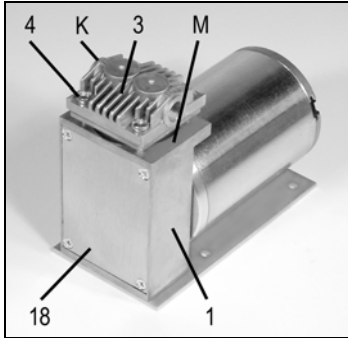

Fig. 3:  
Pump element (single head types)

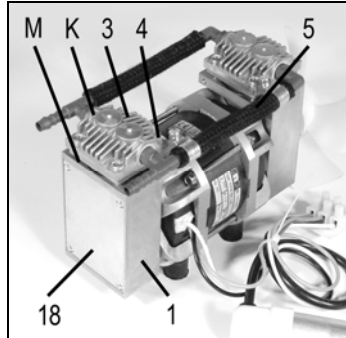

Fig. 4:  
Pump element (twin head types)

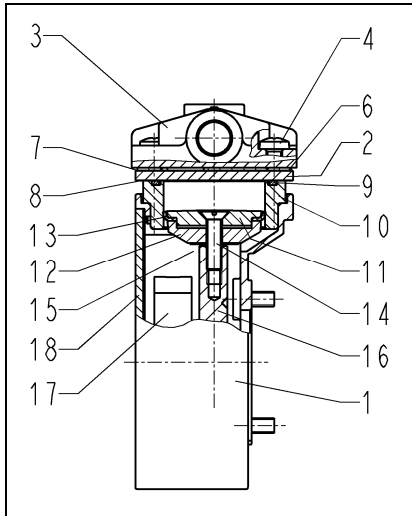

Fig. 5:  
Pump element (all types)

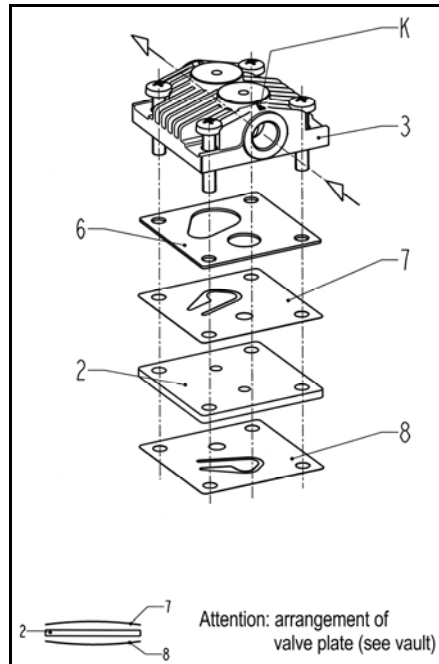

Fig. 6:  
Pump head (all types)

#### Specification

Pos. Description

- 1 Housing
  - 2 Intermediate plate
  - 3 Ribbed head
  - 4 Screw
  - 5 Connection (only twin head models)
  - 6 Gasket
  - 7 Valve Plate
  - 8 Valve Plate
  - 9 O-Ring
  - 10 Cylinder
  - 11 Retainer Plate
  - 12 Support
  - 13 Piston seal
  - 14 Screw
  - 15 Washer(s)
  - 16 Connecting rod
  - 17 Counter weight
  - 18 Cover
- M** Mark  
**K** Compression symbol

The position numbers in the following text refer to figs. 3 to 6.

### 5.1. Changing the piston seal

Parts required	Spare part*	Quantity
	Piston seal	1 (twin head pumps: 2)
	Countersunk flat head screw (14)	2 (twin head pumps: 2)

Tab. 2

\* According to Spare parts list, section 8

Tools required	Tools/Material
	Philips screwdriver no. 2
	Screwdriver (blade width 5,5 mm)
	Phillips screwdriver no. 1
	Felt-tip pen

Tab. 3

In the case of twin head pumps both piston seals should always be changed at the same time.

#### Dismantling

1. In the case of twin head models the connecting pipework between the heads must first be removed.
2. Make a mark (**M**) on the ribbed head (**3**), intermediate plate (**2**), and housing (**1**) with a felt-tip pen (see **M** in figures 3 and 4). This helps avoid incorrect assembly later.
3. Unscrew the 4 screws (**4**) and take off the ribbed head (**3**).
4. Remove gasket (**6**), valve plate (**7**), intermediate plate (**2**) and valve plate (**8**) from housing (**1**).
5. Only for the pump model NPK09 DC: Take off the cover (**18**) after removing the 4 screws securing it.

For this pump type applies: Where reference is made to turning or holding the cooling fan, the necessary operations must be carried out by turning or holding the counter-weight (**17**).

6. Turn the fan to bring the retainer plate (**11**) to top dead center.
7. Pull the cylinder (**10**) upwards to remove it.
8. Hold the fan, loosen the retainer plate screw (**14**) and remove screw, retainer plate, support (**12**) and washer(s) (**16**).
9. Remove the piston seal (**13**) from the retainer plate.
10. Check that all parts are free from dirt and clean them if necessary (see section 6.Cleaning).
11. Check the valve plates for damage (tongues bent, corrosion); if necessary use new ones when reassembling.

#### Assembly

1. Hold the connecting rod (**16**) vertical, and replace the cylinder (**10**) on the pump housing (**1**).

2. Re-assemble the "piston assembly":
  - Lay the new piston seal (13) on the retainer plate (11) with the sealing lip towards the free surface of the retainer plate.
  - Lay the support (12) on the retainer plate/piston seal assembly.
  - Push the new countersunk flat head screw (14) through the assembly, and fit the same number of washers as previously used.
3. Insert the piston assembly (retainer plate, support, piston seal and washer(s) with their screw) into the cylinder from above, on to the connecting rod.
 

The piston seal must not be distorted during assembly. It must make contact with the cylinder all round its circumference.
4. Fasten the "piston assembly" by tightening the screw (14).
5. Reassemble the "head assembly": stack the following parts on top of each other in the order given: ribbed head (3), gasket (6), valve plate (7), intermediate plate (2), and valve plate (8). Fig. 6 shows the correct orientation of the parts, particularly the valve plates, in relation to the compression symbol on the head plate. Both valve plates are identical, and they can be fitted either way up. The intermediate plate can also be fitted either way up.
6. Place the "head assembly" on the pump housing (1) - as a guide to orientation see fig. 3 (single head models) or fig. 4 (twin head models). Reference point is the compression symbol (indicated with a **K** in the diagrams), or the mark (**M**).
7. Tighten the screws (4) at first lightly, then firmly by hand, in a diagonal pattern (max. tightening torque 1.5 Nm).
8. Rotate the fan by hand to check that pump turns easily.
9. Pump model NPK 09 DC only: refit cover (18) to the housing.

For twin head pumps, repeat the operations described for the second head, and replace the connections between the two heads.

If, after changing the piston seal, the specified vacuum is not reached, check the following:

- pneumatic connections for tightness
- for twin head models that the head connections are gas-tight
- if the washer(s) under the support has/have been assembled.

If, after changing the piston seal, the pump produces no flow, check the position and orientation of gasket (6), valve plate (7), intermediate plate (2) and valve plate (8). See fig. 3,4 and 6.

**5.2. Changing the valve plates**

Parts required

Spare part*	Quantity
Valve plates	2 (twin head pumps: 4)



Tab. 4

\* According to Spare parts list, section 8

Tools required

Tools/Material
Philips screwdriver no. 2
Felt-tip pen

Tab. 5

In the case of twin head pumps, both valve plates must always be changed at the same time. The text below describes the operations necessary for one head.

To change the valve plates, the following operations of Section 5.1 *Changing the piston seal* must be carried out:

### Disassembly

1 to 4, 10 and 11.

### Assembly

5 to 8 using new valve plates (2 for each head).

For twin head pumps, repeat the operations described for the second head, and replace the connections between the two heads.

If, after changing the valve plates, the specified vacuum is not reached, check the following:

- pneumatic connections for tightness
- for twin head models that the head connections are gas-tight

If, after changing the valve plates, the pump produces no flow:

- check the position and orientation of gasket (6), valve plate (7), intermediate plate (2) and valve plate (8). See fig. 3, 4 and 6.

If you have any questions about servicing call our technical adviser (see last page for contact telephone number).

## 6. Cleaning

When changing valve plates and diaphragm, inspect all parts for dirt before assembling the pump head, and clean them if necessary.

As far as possible, clean the parts with a dry cloth. Solvents should not be used as they can attack the plastics, and synthetic rubber parts. If a compressed air line is available, blow the parts out with it.

## 7. Trouble Shooting

**Before working on the pump isolate the power supply securely, then check that the lines are not live.**

The following tips for fault-finding are best employed in the sequence shown.

### **Pump produces no flow**

- Thermal switch has operated following over-heating.
  - ▶ Disconnect pump from mains and allow to cool. Trace cause of over-heating and eliminate it.
- Connections or lines are blocked
- An external valve is closed, or a filter blocked.
- Liquid (condensate) has collected in the pump head.
- Piston seal or valve plate is/are worn.
  - ▶ Section 5. *Servicing*.

### **Flow, pressure, or vacuum too low**

- Compare the actual performance with the figures in section 10 or the data sheet.
- There is pressure on the pressure side, and at the same time vacuum, or a pressure above atmospheric, on the suction side.
  - ▶ The pump is not designed for this condition.
- The internal diameter of connecting tubing or connected components, or connected components is too small, or they are restricted.
  - ▶ In order to measure performance, the pump must be disconnected from the system (small diameter tubing or a valve can significantly affect performance).
- There is a leak at a connector, in a line, or in the pump head.
- Piston seal or valve plate is/are worn, or dirt is in the head (see section 5. *Servicing*).

If the pump does not operate properly and you cannot find any of the above faults, send it to the KNF Service Department.

## 8. Spare parts

Pos. Nr*	Description	Order-No.
(2)	Intermediate plate	025523
(3)	Ribbed head	054402
(4)	Screw	005112
(5)	Connection for NPK 09.1	026178
	NPK 09.1.2 (suction side)	
	Connection for NPK 09.2	026179
	NPK 09.1.2 (pressure side)	
(6)	Gasket	052650
(7)(8)	Valve plate	052649
(9)	O-Ring	025547
(10)	Cylinder	025528
(11)	Retainer Plate	025530
(12)	Support	025532
(13)	Piston seal	025531
(14)	Screw	110725
(15)	Washer	006886

Tab. 6: Spare Parts

\*according to figure 5

## 9. Accessories

Description	Order-No.
Silencer/Filter	072233
Hose Connector 1/8 MPTM, ¼ HID	072235

Tab. 7: Accessories

## 10. Tables

Pump type	Max. permissible operating pressure (bar g)	Ultimate vacuum (mbar abs.)	Delivery rate* (l/min) at atm. pressure
UNPK09	7	100	12
UNPK09DC	7	100	15
UNPK09.1	-	100	24
UNPK09.2	7	-	24
UNPK09.1.2	7	100	24

Tab. 8: Pneumatic Data

\*Litre at STP

## 11. Product Return

- ➔ KNF provides warranty and non-warranty repair services for all products.
- ➔ A Return Material Authorization (RMA) number is required for all product returns.
  - To receive an RMA number, submit a completed Decontamination Declaration form to [rma@knf.com](mailto:rma@knf.com)
- ➔ The Decontamination Declaration form can be obtained from our website or by contacting KNF Technical Services.
  - <http://www.knf.com/pdfs/decontamdec.doc>
  - Phone: 609-890-8600
- ➔ Product return instructions will be provided when the RMA is issued.

KNF Neuberger, Inc  
2 Black Forest Rd  
Trenton, NJ 08691-1810

Phone 609-890-8600  
Fax 609-890-8323

[www.knf.com/usa.htm](http://www.knf.com/usa.htm)



